

**Updated 15<sup>th</sup> February 2010:** Mr. Stephen M. Hargreaves / Chairman & CEO

[Steve.hargreaves@internationalinnovations.com.au](mailto:Steve.hargreaves@internationalinnovations.com.au)

Phone: +61 (0) 411-879-024

## “OTELLO™-Heat Recovery Engine-System Overview”

**Patent Serial Number:** PCT/EP2009/053524

**Owner:** International Innovations Limited (IIL) (100% owner)

**Filing Date:** March 25, 2009

**Priority claimed:** Europe, No. 08102877.1 of March 25, 2008

**Internal ref:** OTELLO-2 (thermal hydraulic generators)

**Registered Inventor:** Stephen M. Hargreaves

**Title: “Method for converting thermal energy into mechanical work”.**

The present invention relates to a method for converting thermal energy into mechanical work. Such method includes the following steps:

- pressurizing a hydraulic medium in a hydraulic circuit;
- converting the pressure of the hydraulic medium into mechanical work

- **HYDAC** International Group [www.hydac.com](http://www.hydac.com) exclusive worldwide preferred supplier for all parts Hydac can supply worldwide are for Otello™ mainly the “Bladder and or Piston Accumulators”. The heart of Otello™ !
- **HONEYWELL** International [www.honeywell.com](http://www.honeywell.com) preferred suppliers for Control systems, instrumentation, valves and variable speed drives, as well as refrigerant gas. The brain!
- **SONDEX** [www.sondexaustralia.com.au](http://www.sondexaustralia.com.au) preferred supplier in Australia for heat exchangers for transferring the heat energy from the source across to Otello™ is the fuel for making clean electricity.
  - ✓ **First built 2008 concept proven** in Germany at [www.big-biogas.de](http://www.big-biogas.de)!
  - ✓ **STANDARD “Off-The-Shelf” PARTS and REFRIGERENT/GASES** from international companies worldwide OLAER & HONEYWELL. (All components are off the shelf, no special manufacturing of unique parts, big cost saving!)

- ✓ **Markets worldwide:** Coal fired Power Stations waste 60% of fuel is emitted into the atmosphere as “waste heat energy”. Industrial waste energy from making all Metals, Glass, Plastics, Rubber, Processed Foods, Desalination Plants, Textiles, and more. Also connects to heat from Solar systems that can create heat from +80C up to +220C are commercially available.
- ✓ **Technical Development** In Australia, calculations for Phase 1 for OTELLO™ 1 Mega Watt system commenced 18<sup>th</sup> May 2009 at Newcastle University commercial arm known as Newcastle Innovation Limited (NI). Three working fluids were considered in this theoretical study: R245fa, R410a and CO<sub>2</sub>, with cold sink temperatures of 25 °C, 25 °C and 20 °C respectively. Based on these preliminary calculations the *theoretical* efficiency of the OTELLO™ was found to be in the range 6.4 – **13.7% for R245fa**, 3.4% – 12.2% for R410a, and 0.1 – 8.0% for CO<sub>2</sub>.  
[www.newcastleinnovation.com.au/investment/energy.html](http://www.newcastleinnovation.com.au/investment/energy.html)

## Energy and the Environment

Newcastle Innovation delivers access to world leading research in renewable energy that aims to develop next generation technologies for energy production, and sustainable processes for preservation of the environment.

The University of Newcastle's has a dedicated priority research centre for energy which aims to provide new opportunities flowing from the interaction between industry, government agencies and university researchers interested in the growing field of clean and sustainable energy production.

The Energy and the Environment (EnE) program area, lead by Associate Professor John Lucas, concentrates on Sustainable and Integrated waste processing/utilisation with energy recovery and generation.

Newcastle Innovation provides industry access to the Research centres state of the art laboratories and equipment. By working closely with industry, Newcastle Innovation provides exceptionally high financial, social and environmental return on investment.

## “PISTON” OTELLO™

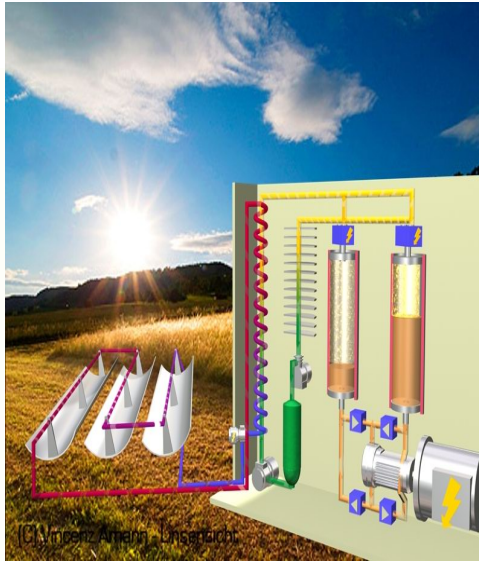
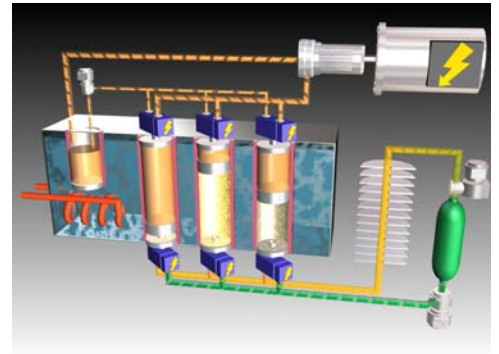
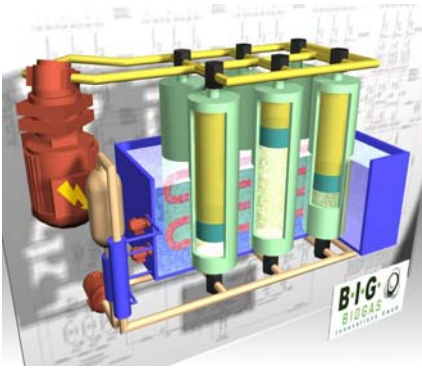

## “BLADDER” OTELLO™

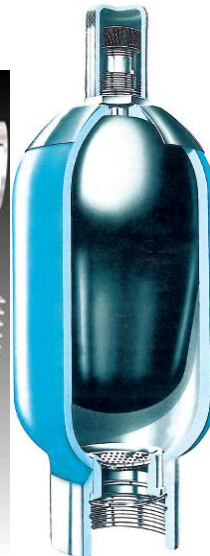
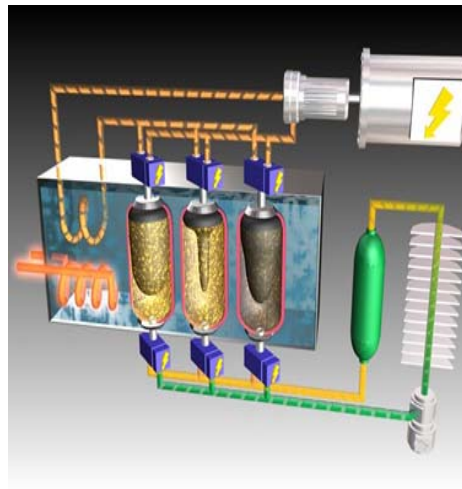

## 1. INTRODUCTION

The *Otello*<sup>™</sup> is a patented system 100% owned by *International Innovations Limited* (IIL) [www.internationalinnovations.com.au](http://www.internationalinnovations.com.au) . The *Otello*<sup>™</sup> technology is the latest addition to the family of waste heat recovery and power generation systems owned by IIL. The system was protected by European patent during March 2008 after other patents dating back to 2004 include AMPS, EUROAMPS, MOREAMPS. This document provides an overview of the *Otello*<sup>™</sup> technology, including a description how the system works and its beneficial features, and applications of the product.

*Otello*<sup>™</sup> uses standard parts available from HYDAC & HONEYWELL international around the world. IIL offers those who are licensed to use our patented products they can build *Otello*<sup>™</sup> and or *Moreamps* systems for converting heat energy into electricity. *Otello*<sup>™</sup> unique feature is the ability to use low temperature heat sources!

*Coal fired Power Stations waste around 60% of fuel is emitted at between +120C to +150C into the atmosphere as waste heat energy. ( waste heat energy is a reliable and biggest source of renewable energy)!*

*From Engines 65% of fuel is wasted i.e. 35% out the Exhaust at +350C and out the water Cooling system is 25% at +87C and 5% is ambient loss.(recoverable waste energy)!*

***OTELLO*<sup>™</sup> 50kW/e was first built and concept proven in Germany 2008. Today we have interest from Energy Companies, Power Stations, manufacturers of Metals, Solar, Engines, interested in *Otello*<sup>™</sup> and *Moreamps* thermal hydraulic generators.**

## 2. HOW the “*OTELLO*<sup>™</sup>” heat recovery engine WORKS

The *Otello*<sup>™</sup> system is a method for converting energy from a heat source into a more useful form, such as electricity. *Otello*<sup>™</sup> has been designed to recover energy from low temperature heat sources. The principle that drives *Otello*<sup>™</sup> is that a closed vessel containing a fluid will become pressurised when it is heated. With an appropriate fluid, high pressures (31bar, 38bar, 47bar, 75bar and 112bar) can be reached at the available temperature and selection of gas. This high pressure can then be used to drive a fluid turbine, thus converting heat energy into useful electrical energy.

Critical to the performance of the machine is the selection of a working fluid that generates sufficiently high pressure from the available heat source in cold and hot climates. The refrigerant known as R245fa is the preferred working fluid at +150C.

A key aspect of the *Otello*<sup>™</sup> system is the use of bladder or piston accumulators (supplied by *Hydac International Group*, which are pressure vessels containing a flexible bladder or piston dividing the total volume into two separate chambers. Gas & Fluid circuits). In *Otello*, the

refrigerant/gas is heated and vaporises inside the accumulator, and this high pressure is then used to push fluid/hydraulic medium (such as oil or water) inside the bladder or on top of the piston. This produces a flow of high pressure hydraulic fluid, which is calculated using Honeywell valves, flow controls and computer for the correct FLOW RATE to be used to run a machine. It is this process that allows the *Otello*<sup>TM</sup> system to convert thermal energy into mechanical/electrical energy.

The *Otello*<sup>TM</sup> therefore has two main systems: (1) a Refrigerant Circuit that controls the heating, pressurisation and circulation of the gas, and (2) a Hydraulic Circuit that converts the high pressure generated by the gas into a useful mechanical / energy output, as shown in Figure 1.

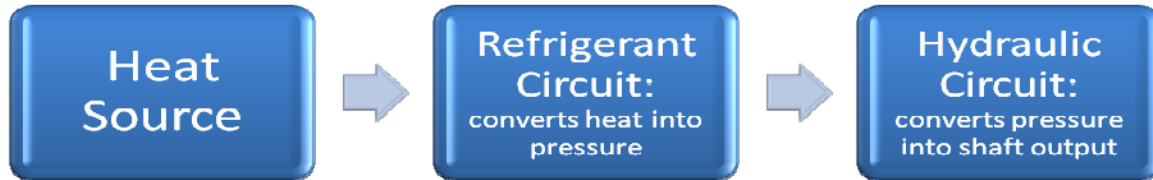
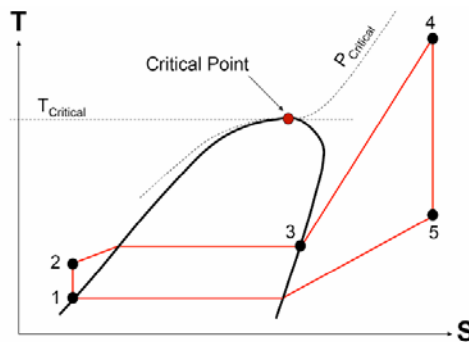

Figure 1 – *Otello*<sup>TM</sup> includes a Refrigerant Circuit and a Hydraulic Circuit.



**Schematic representation of the Otello heat engine on a T-S diagram.**

As can be seen above from the Otello thermodynamic cycle in the model begins with pumping the working fluid from the saturated liquid State 1 to sub-cooled liquid State 2. The heat addition phase then commences. The energy added to the Otello system during the heat addition phase originates from a heat source. Rather than direct heat exchange between the source and the accumulator cylinder, the thermal energy of the source is used to heat up a bath of water or oil in which the accumulator cylinders are placed. The heat addition process initially takes place between States 2 and 3 under constant pressure where as shown in Figure 1 the working fluid experiences some slight expansion. Once the working fluid reaches the saturated vapour State 3 the heat addition process continues under constant volume. As a result, the pressure and temperature of the working fluid rise until it reaches its maximum temperature at the superheated State 4. The working fluid is then isotropically expanded to State 5. The volume of the working fluid during the expansion phase increases dramatically causing the piston (or bladder) to move, in turn, forcing the hydraulic liquid out of the accumulator generating mechanical work. Upon full expansion, the process of heat rejection to a cooling medium begins at constant pressure (between States 5 and 1) and the cycle comes to completion once the working fluid reaches State 1. The processes described above are then repeated.

It should be noted that the T-S diagram shown suggests that the Otello heat engine can be operated at temperatures higher than the critical temperature of the working fluid provided that the maximum cycle pressure is maintained at levels below the critical pressure.

## 2.1 ACCUMULATORS AND OTELLO™ (Bladder and or Piston)

Hydraulic accumulators are important components in the operation of the *Otello*™ system. Accumulators are the heart of *Otello*™ and provide the link between the Gas Circuit and the Hydraulic Circuit, and perform two critical functions.

These are:

- (1) heating and pressurising the gas, and
- (2) transferring power (pressure) from the gas to the hydraulic medium. The physical layout and orientation of one accumulator is shown in Figure 2. The Bottom Chamber is plumbed into the Refrigerant Circuit and the Flexible Bladder is connected (via the top port) to the Hydraulic Circuit. Thus, the Bottom Chamber contains gas and the bladder contains the hydraulic medium (water or oil).

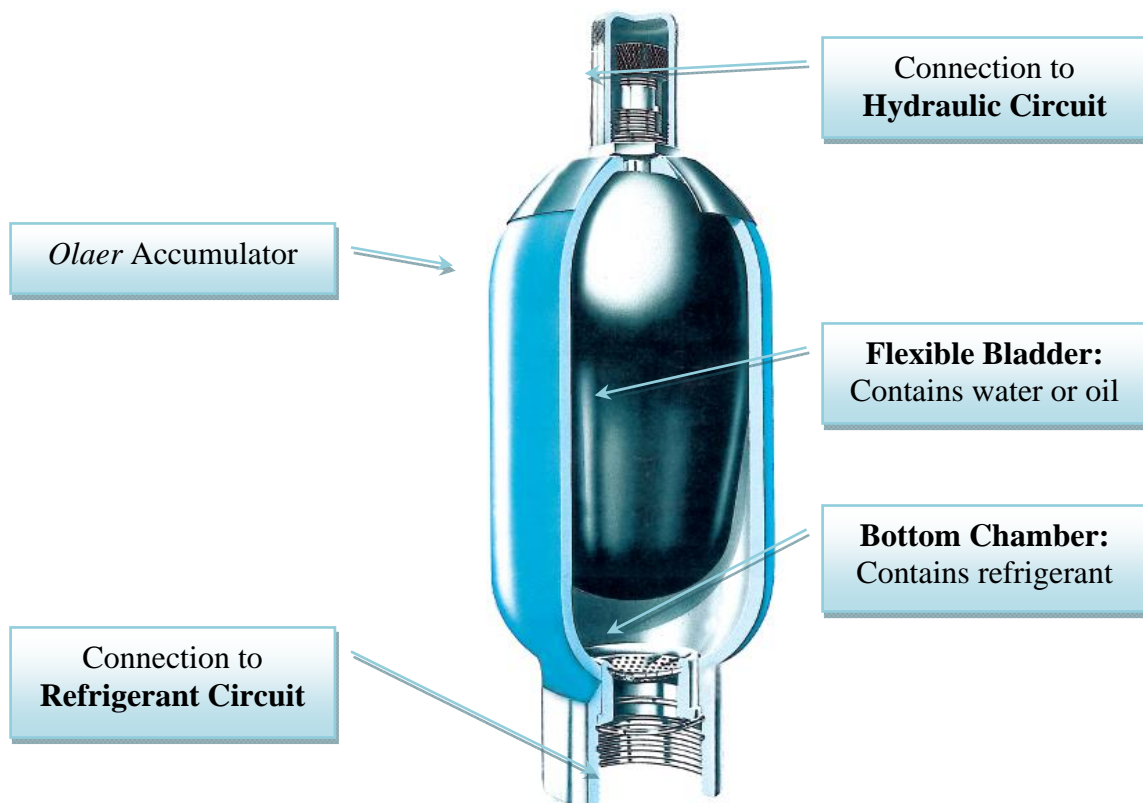
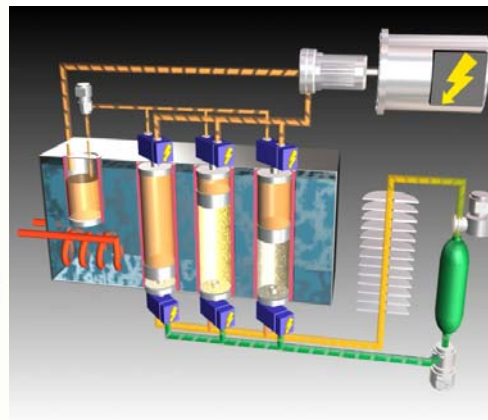
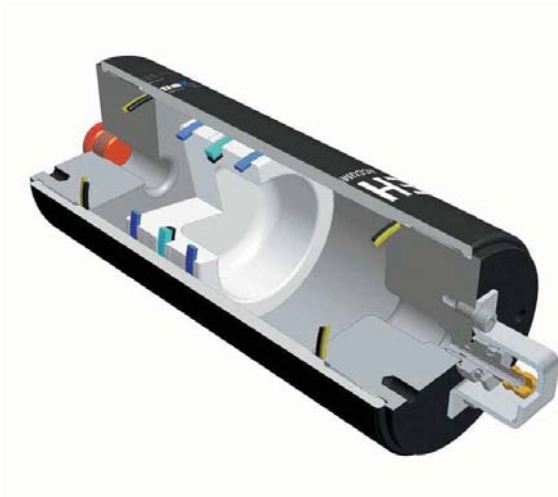

Figure 2 – Accumulator orientation and layout (not to scale).

The standard bladder from HYDAC can be filled with fluid/oil and expand to occupy the required volume inside the pressure vessels with Honeywell controls. When calculating the volume required for the rate of flow in the fluid circuit HYDAC bladders can be fitted with a restrictor (see last page) for the volume limit required when filled with water or oil to the required ratio between GAS side & FLUID side in order to minimise stretching and prolong service lifetime. Best of all is HONEYWELL valves and controls can monitor and control the

appropriate volume of fluid into the bladders or on top of the piston accumulators. At the beginning of the heating/pressurisation process, with the bladder filled to 30 – 50 %, the bottom chamber is partially filled with low temperature, liquid gas. With both the top and bottom valve/ports closed, heat is applied to the accumulator. This causes the chosen gas / refrigerant to increase in temperature and create vaporised pressure. After a period of time, when the gas has reached its sufficiently high pressure, the top port is controlled to be opened by design or Honeywell controls and the water or oil is expelled from the bladder or piston under high pressure. In this way, the accumulator facilitates (1) the heating and pressurisation of the gas, and (2) the transfer of this pressure to the hydraulic medium. It is this function that is most important to the operation of *Otello*.



- HYDAC Piston Accumulators (above) range in size from: 0.01 litre to 2,500 litre on special request. This enables *Otello*<sup>TM</sup> to be built in modular form in smallest or largest system. Can cascade the system to optimise the use of the heat source.

## 2.2 WATER BATH/HEAT STAND

In order to provide a continuous output of high pressure hydraulic fluid, it is necessary to have multiple accumulators heating/pressurising and discharging in a time-shifted manner. The accumulators are housed in an array that is enclosed in an insulated steel vessel, as shown in Figure 3 (below). The total number of accumulators will vary depending on the desired power output. Importantly, the steel enclosure is filled with water or thermal oil, meaning that the accumulators are completely submerged in a water bath. The heat source is used to maintain the temperature of the thermal bath at the highest possible value.

For temperatures above +100 °C, additives such as Glycol may be used to raise the boiling point, or the water may be replaced with another fluid (such as thermal oil with a boiling point of 400 °C) in order to prevent boiling.

This arrangement is convenient because there are many existing systems for transferring heat from a heat source to a liquid medium. For example, there are commercially available Heat Exchangers to connect Diesel Engine exhaust heat, and from Power Stations, Industrial or Solar.

*Otello™ uses standard components, refrigerant / gases and control systems which are proven, warranty is provided from the component suppliers HYDAC & HONEYWELL.*

*The system below was using 35 litre accumulators producing 50kW/e.*

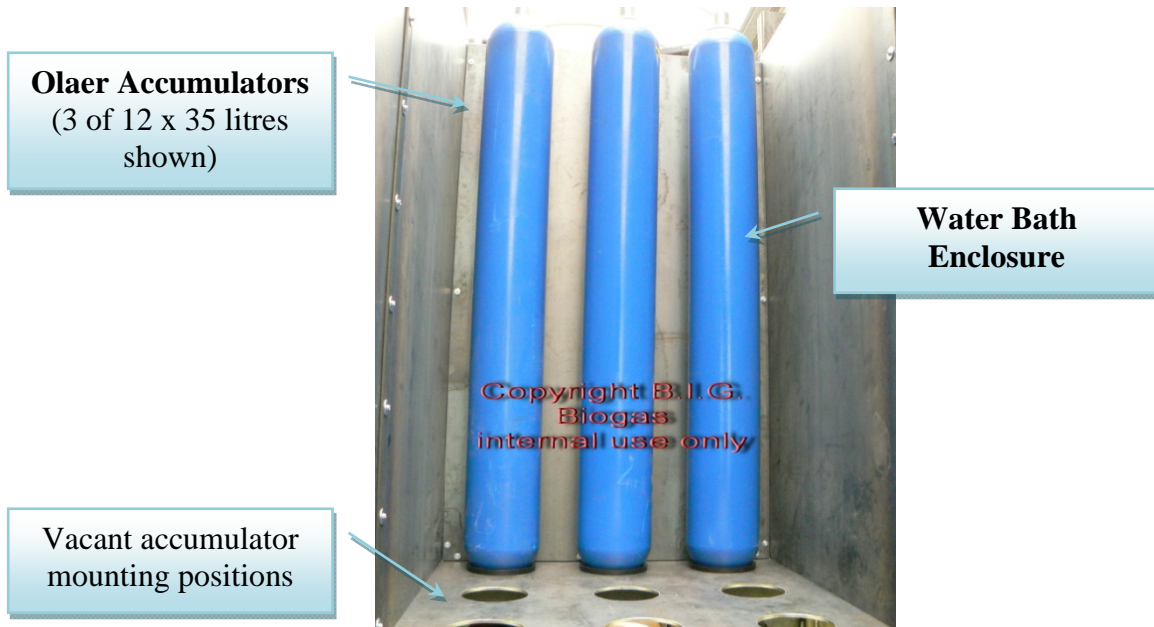

*Figure 3 – The Otello™ Water Bath or Stand.*

The accumulators in the first built *Otello™* were completely submerged in the hot water bath and therefore are continuously heated over their entire surface area.

It is now considered only the gas side needs heating and the bath can be built as a heat stand to only cover the bottom half of the pressure vessels level with the gas circuit below the bladder or piston.

During the heating and pressurisation of the gas (described in the previous section), the heat input is from the hot water bath, through the entire outer shell of the accumulator. The hot water bath may be stirred (with an impeller, for example) to increase heat transfer rates, in the same way as a ‘fan forced’ oven does for hot air. The hot water bath/stand also provides a large thermal reservoir that will tend to dampen out fluctuations in input temperature, and will allow the *Otello™* to generate power for some time after the heat source becomes unavailable.

### **2.3 OTELLO™ SCHEMATIC**

The *Otello™* schematic is shown in Figure 4. As is shown, the system is compatible with any heat source that is capable of maintaining the desired temperature of the water bath. More details are provided in the following sections on the operation of the Gas / Refrigerant and Hydraulic Circuits to support the continuous operation of *Otello*.

### **2.4 REFRIGERANT CIRCUIT (R245fa)**

The purpose of the refrigerant system is to facilitate the heating and pressurisation of the R245fa, and then to ‘reset’ the R245fa for the next cycle after it transfers power to the hydraulic fluid. As

the first step in the cycle, shown in Accumulator 3 in Figure 4, liquid R245fa is pumped into the bottom chamber of an accumulator, partially filling it. The accumulator is then sealed, as shown in Accumulator 4, and the R245fa is given time to heat and pressurise. After reaching its maximum temperature and pressure, the R245fa then transfers power to the hydraulic system, when the top (bladder or piston) chamber of the accumulator is opened, as shown in Accumulator 1. The expanded R245fa is then vented from the bottom chamber into the remainder of the refrigerant circuit, as shown in Accumulator 2. At this point, the R245fa is a hot vapour at high pressure. It then passes through an expander, which drops the pressure, and then through a radiator, which causes the R245fa to condense back to the liquid phase. This closes the cycle and the liquid R245fa returns to the refrigerant pump and back to the accumulators. In this way, as the R245fa moves through the refrigerant circuit, it receives heat energy as an input, and transfers mechanical energy (pressure) to the hydraulic fluid inside the bladder accumulators as an output.

### **2.5 HYDRAULIC CIRCUIT (WATER OR OIL)**

The purpose of the hydraulic system is to convert the pressure generated by the gas into a useful form, such as mechanical energy in a rotating shaft (which can turn a generator to make electricity). As shown in Accumulator 2 in Figure 4, while the gas is being vented into the expander, the bladder/piston at the top of the accumulator is simultaneously filled with hydraulic fluid (water or oil). The pressure to fill the bladder is supplied by a low voltage pump downstream of the hydraulic turbine. The bladder/or piston accumulators using Honeywell flow controls the total accumulator volume for the hydraulic circuit. The bladder is then sealed (and its volume remains constant) as the bottom chamber is filled with gas and pressurised as described previously, until the maximum temperature and pressure is reached. Then, as shown in Accumulator 1, the bladder/or piston is connected to the hydraulic circuit, and the water or oil is expelled from the accumulator under high pressure and driven through a liquid turbine (or other hydraulic motor).

After passing through the turbine, the liquid then returns to the accumulators for the next cycle. The hydraulic fluid is maintained at a temperature similar to the water bath, in order to minimise thermal losses. No phase change occurs in the hydraulic circuit; the fluid remains liquid throughout the entire process. The use of multiple accumulators allows the flow of high pressure hydraulic fluid to be maintained continuously to drive an Oil Motor or Pelton Turbine to generate electricity with Honeywell controls.



More photos of *Otello*<sup>TM</sup> 50kW/e built in Germany see IIL website in products or click on the following link <http://www.internationalinnovations.com.au/otellophotos.php>

#### **OTELLO<sup>TM</sup> technology:**

- LOW COST using standard parts available around the world.
- MODULAR, Flexible and Scalable in design from 1kW to any size using HYDAC pressure vessels with bladders or pistons from 0.01 litre to 2,500 litres. Build 10MW by connecting in cascade design i.e. 10 x 1MW OTELLO's or 100MW by connecting 10MW x 10, whatever until all waste heat energy is used for optimum efficiency.
- Low operation and maintenance requirements – monitored by control system and planned maintenance servicing periods as recommended by HYDAC & HONEYWELL,
- Non-combustion process,
- Zero toxic by-products,
- Zero emissions,
- Zero fossil fuel requirements,
- Modular and mobile, Carbon neutral OTELLO,

#### **RECOMMENDED MATERIALS**

*OTELLO is modular and can be built to any size from smallest to largest power generation system* OTELLO heart is using the following Hydac [www.hydac.com](http://www.hydac.com) recommended materials for heat and gas selection using a wide range of sizes:

- Refrigerant R245FA use bladder material: Nitrile (M25) for - 15°C to + 110°C
- High Pressure Gas NH<sub>3</sub>, Anhydrous Ammonia gas use bladder material: Polychloroprene (M50) for temperature ranges - 15°C , +100°C
- **Also if we had to choose 1 compound as a compromise to suit all it would be Butyl (M40).**

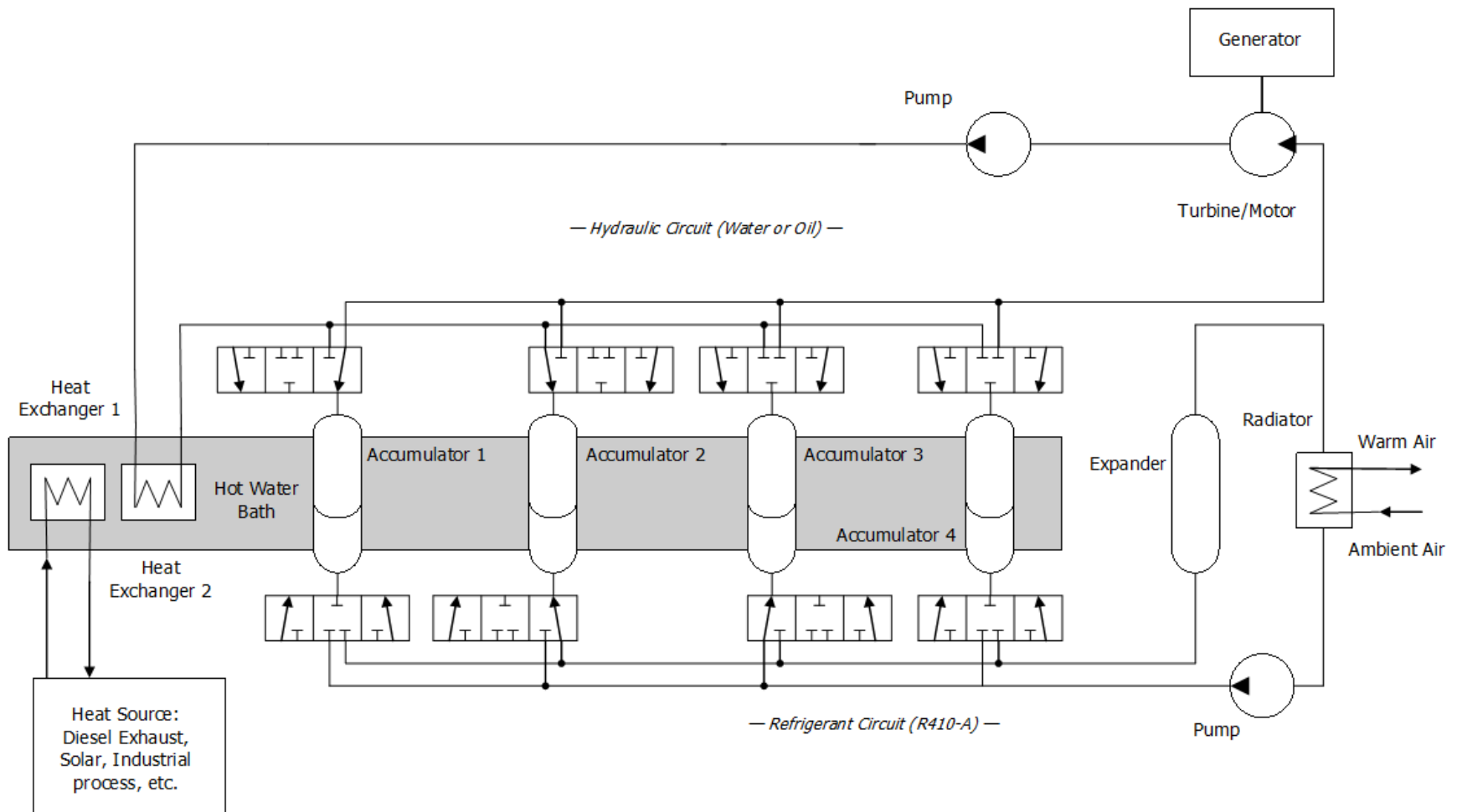
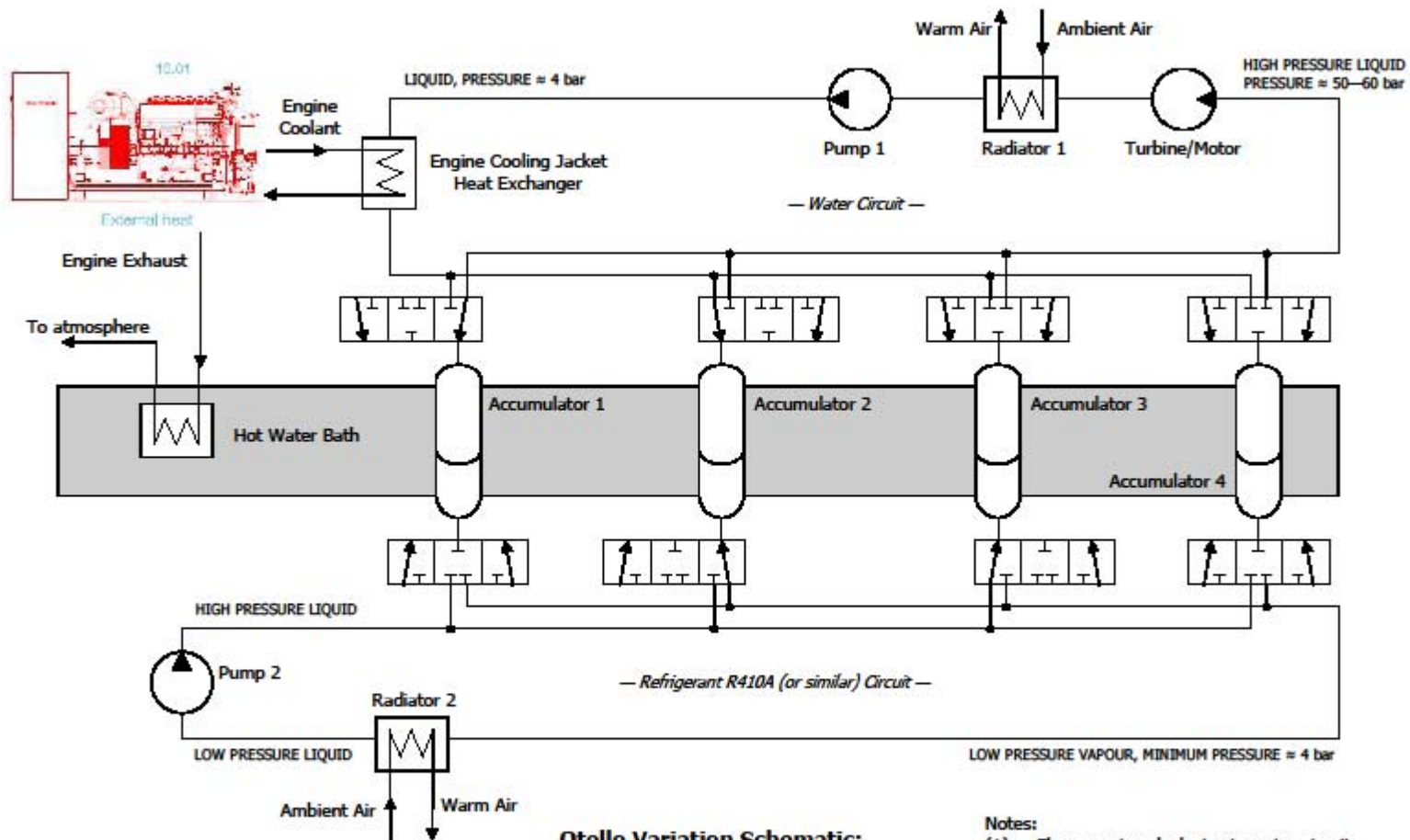
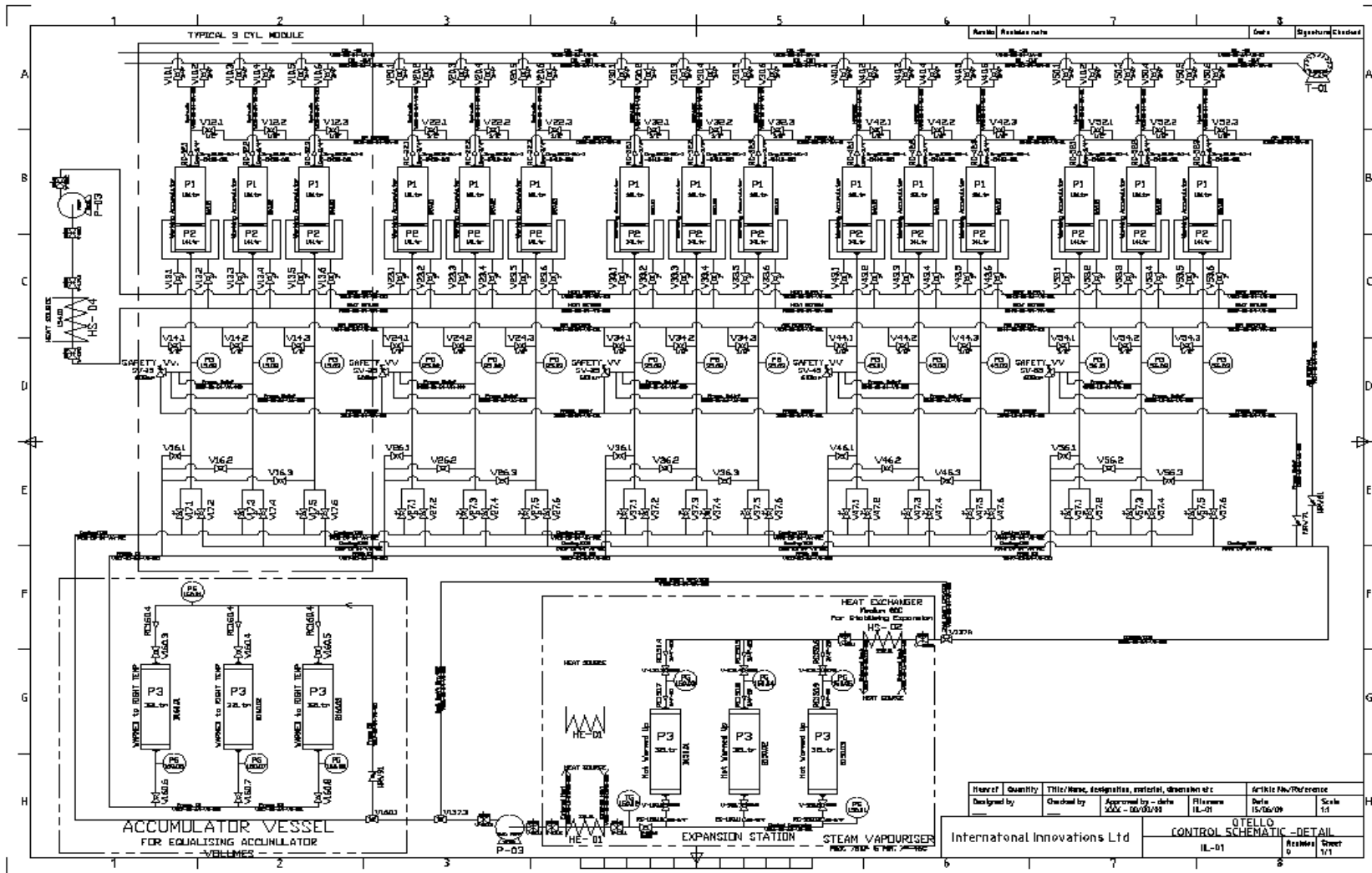

Figure 4 – Simplified Otello™ Schematic



**Otello Variation Schematic:**  
**Proposed by Dr. N. Ward**  
 11 March 2008



Number	Quantity	Title/Name, designation, material, dimension etc	Article No./Reference
Designed by	Checked by	Approved by - date	Issue No. / Date
		2004-09/09/09	IL-01 / 15/06/09

International Innovations Ltd

**OTELO**  
**CONTROL SCHEMATIC - DETAIL**  
 IL-01  
 Revision 15  
 Sheet 1/1

### 3. CONTROL SYSTEM

The operation of all the valves, pumps and other subsystems will be co-ordinated by an autonomous control system. The control system may take as inputs external information including electrical load, heat source temperature and ambient temperature, as well as information from within the *Otello*<sup>TM</sup> such as valve positions, fluid temperatures and pressures, and mass flow rates. The control system will have an embedded software program that takes these (and, likely, other) inputs and produces logical outputs to ensure the continued, smooth operation of the *Otello*<sup>TM</sup> at the desired power output level. The control system will also have a communications link with a service computer (operated by, for example, the licensee for that region), for the scheduling of maintenance and other tasks. It is intended that the control system will perform these or other similar tasks:

1. Run the *Otello*<sup>TM</sup> under normal operating conditions. This will involve start-up, steady operation and shut-down procedures governing such events as valve opening and closing times, and the management and control of fluid flow. The control system software will change its outputs to dynamically respond to changes in heat source temperature, ambient temperature, load conditions and other parameters to facilitate the continued operation of the *Otello*<sup>TM</sup> under normal conditions.
2. Detect any abnormalities and/or failures and compensate to allow the *Otello*<sup>TM</sup> to continue to produce power output. For example, the control system may be able to detect when some subsystems are responding slower than usual, which may indicate a fault is about to occur. The system may be able to detect the failure of a valve or other component. In either of these (or similar) cases, the control system may be able to compensate by, for example, shutting down the operation of one of the accumulators in order to prevent further damage and allow the overall system to continue operation.
3. Report any abnormalities and/or failures to the service centre via the communications link. Any faults that are detected as described previously will be reported to the service centre via an automated telephone or internet communication. This will enable the automated scheduling of servicing, repairs, or replacement of parts. This would be critical to the development of a sophisticated ongoing maintenance and service program, which may be an attractive value-added product to be offered by local licensees.
4. Report the number of kWh of electricity produced by the *Otello*<sup>TM</sup> system. The control system may be used to periodically report the number of kWh of electricity that has been produced. This may be especially valuable for end users concerned with any form of *carbon auditing*, in which the output of the *Otello*<sup>TM</sup> must be carefully quantified in order to offset other carbon emissions, generate carbon credits, or redeem Government financial incentives for the generation of electricity in this way.

5. Upload new software to the machine from the service centre. If, at some time after the installation of an *Otello*<sup>TM</sup> system, some improvements are made to the control software, this can be passed to the control system via the communications link. It is foreseeable that continued testing, optimisation and service experience will lead to further development and sophistication of the control software. For example, it may be shown that the performance of the *Otello*<sup>TM</sup> can be improved by filling the bladders to a different percentage, or by adjusting the timing of some valves. With the communications link, these improvements can be immediately uploaded to all the *Otello*<sup>TM</sup> systems in operation, so that all systems, regardless of age, are kept up-to-date with the latest version of the control system.

In these ways, a sophisticated control system will add robustness and flexibility to the *Otello*<sup>TM</sup> system. It will offer many value-added products for the regional licensees, such as servicing or software updates, and will improve the outcomes for the end users, through improved performance, greater reliability, and extended system lifetime.

#### **4. BENEFITS**

The key advantages of the *Otello*<sup>TM</sup> system include:

1. The system is compatible with a variety of heat sources. Further, the use of the water bath greatly simplifies interfacing with the heat source. Many commercially available heat exchanger systems will be suitable. For example, when the *Otello*<sup>TM</sup> is driven by the waste heat from diesel engine, a standard exhaust heat exchanger could be used to heat the water bath. The same *Otello*<sup>TM</sup> system could be used in other applications by merely replacing this heat exchanger with one compatible with the heat source (gas-liquid heat exchanger, liquid-liquid heat exchanger, etc.). This modular approach will tend to reduce the cost of adapting the *Otello*<sup>TM</sup> system to different heat sources.
2. The system can easily be adapted to suit different temperature limits. Within the constraints of material compatibility, the system can accept a variety of working fluids in the Refrigerant Circuit, hydraulic media in the Hydraulic Circuit, or heat transfer fluids in the water bath. These fluids can be selected to ensure the best match for the heat source temperature and local average ambient temperature. Depending on material compatibility, standard hardware may be sufficient, since the layout of the fluid circuits is independent of the specific choice of working fluid. This will lead to greater standardisation, which will tend to reduce costs and manufacturing complexity. For example, the same physical components may be suitable for applications in both Europe and Africa; these systems may simply need to be filled with different fluids to ensure optimal performance under the different local conditions. Also, refrigerant fluids are under continual development by their manufacturers, so as new products become available, with extended lifetimes, less environmental impact or improved thermal properties,

these new fluids may be compatible for immediate use in existing *Otello*<sup>TM</sup> systems in service.

3. The refrigerant is heated while it expands. This tends to maintain the temperature and pressure. Heating the working fluid while it is expanding is thermodynamically ideal and, for example, is incorporated into the high efficiency Stirling and Ericsson cycles. Even in large power stations, this can only be approximated, because, due to engineering practicality, steam cannot be heated whilst it is passing through a turbine. In that case, the process is approximated by reheating the working fluid in discrete steps, in between separate expansion processes.
4. The expansion process occurs slowly. This is a closer approximation of an ideal, 'reversible' process compared to some other systems, which tends to increase efficiency. The slow operation of the system will also tend to extend the fatigue life of some components and minimise or delay degradation of the bladder materials.
5. The use of bladder or piston accumulators is likely to result in a highly efficient expansion process. Using the accumulators in this way to pressurise water or oil and drive a liquid turbine is likely to recover approximately 70 % or more of the motive power produced by expanding the refrigerant. Liquid turbines typically have efficiencies of over 90 %. In contrast, for a vapour turbine operating under similar conditions, their efficiency may be as low as 30 %. This gives *Otello*<sup>TM</sup> a significant advantage over many competing low-temperature waste heat recovery technologies, such as Organic Rankine Cycles. In addition to a possible efficiency advantage, the use of bladders / pistons to expand the refrigerant also removes a common engineering problem associated with the use of vapour turbines. Vapour turbine blades suffer from erosion if the working fluid condenses during the expansion process. This will not affect the bladder/piston system, and the expansion of a wet vapour is unlikely to have any negative effects. This makes the bladder/piston system more robust against changes in operating conditions than vapour turbines.
6. The system can be assembled from commercially available, off-the-shelf components. In contrast to vapour turbine systems, *Otello*<sup>TM</sup> requires no specialised parts. Instead, *Otello*<sup>TM</sup> can be built from robust components that each has their own history of product development and optimisation, and years of proven service (decades of service in the case of the accumulators). This will tend to extend maintenance lifetime, as the *Otello*<sup>TM</sup> will inherit the reliability and maturity of its individual components. Further, the use of commercially available parts will tend to reduce the cost of the machine through (a) minimising product development costs built into the final price and (b) making use of the existing manufacturing, mass-production and assembly techniques already in place for each of the components. This feature may also simplify maintenance procedures and reduce maintenance costs through existing familiarity with the various components.

## 5. APPLICATIONS

As has been noted, the *Otello*<sup>TM</sup> system is highly versatile and compatible with a wide variety of heat sources. These may include:

1. Stationary Diesel, Gas or Biomass Generators: An early application of the *Otello*<sup>TM</sup> system was built in Germany claimed 24% to 27% efficiency and is likely to be in the recovery of the waste heat generated by stationary diesel generator sets. As an example, for a 500 kW diesel engine, a standard exhaust system heat exchanger can recover approximately 500 kW of waste heat, which can be used to power an *Otello*<sup>TM</sup>. With an optimised system operating at the maximum temperature of +200°C, an additional increase in the output of the generator for the same fuel use (or similar reduction in fuel use for the same output) may be obtained. This system would be particularly attractive to the owners of stationary continuously running diesel generators that provide primary power. The system will become increasingly financially attractive as fuel prices continue to rise, and as either penalties for carbon emissions or incentives for emissions reductions are introduced.
2. Solar Thermal: Solar thermal power involves generating electricity using the *heating* effect of sunlight (as distinct from the photovoltaic effect). Concentrated sunlight can generate extremely high temperatures. Temperatures well in excess of 200 °C are common. The most mature solar thermal technology is the parabolic trough solar concentrator, in which a heat transfer medium (such as water or thermal oil) is heated as it passes through a pipe situated at the focal line of the concentrator. The heat transfer medium is typically used to provide heat input to a steam or organic Rankine Cycle system to generate electricity. However, the heat transfer medium could instead be used to provide heat input to the *Otello*<sup>TM</sup> water bath. This could be achieved either directly, by passing the heat transfer medium through the water bath, or indirectly, via a liquid-liquid heat exchanger. The *Otello*<sup>TM</sup> system may be advantageous due to its operation at lower temperatures. This may simplify the heat transfer system for capturing heat from the solar concentrators, by reducing pipe wall thicknesses, mitigating material/temperature compatibility issues, and reducing radiation losses.
3. Power Station: Conventional coal power stations waste heat through cooling/condensing systems has +35C hot water heading for the lake or river, in exhaust flue gasses +120C to +150C. For example, the exhaust flue gas temperature of the Kogan Creek power station in Queensland, Australia, is +120°C. This waste heat can be captured and input to an *Otello*<sup>TM</sup>, through conventional heat exchanger systems. In addition to the increase in electrical output obtained, this would reduce the thermal impact on the local environment and, if heat is extracted from the condensing system, may also reduce the power scavenged by that part of the power plant. This would be especially the case at the Kogan Creek power station, where heat is rejected through an air-cooled condenser in order to reduce water consumption. The trade-off is that this air-cooled system scavenges more power from the main plant compared to water-

cooled systems. Therefore, using the waste heat from the cooling system in an *Otello*<sup>TM</sup> would not only allow the direct generation of additional electricity, but may also tend to reduce the power consumed by the air-cooled condenser, since would be a smaller heat rejection load.

4. Power Station / Solar: In some cases, such as those involving the recovery of waste heat upstream of the condensing system of a power station, the temperature at which energy is recovered may not meet the minimum requirements of the *Otello*<sup>TM</sup> system. In these cases, it may be favourable to use a solar concentrator field (such as the system described previously) to reheat the heat transfer medium to the minimum temperature required by *Otello*<sup>TM</sup>. This arrangement would greatly reduce the required size – and cost – of the solar concentrator field, compared to a stand-alone solar thermal power station of the same electrical output. This is due to the significant amount of preheating provided by the power station waste heat.
5. Geothermal Power: Geothermal power involves using heat obtained from underground to generate electricity. The *Otello*<sup>TM</sup> has two potential uses in this application. It could be used as a secondary system to capture the heat wasted by a primary power generation system, such as a steam or organic Rankine Cycle, in a similar way to that described above for conventional power stations. Alternatively, the *Otello*<sup>TM</sup> could be used as the primary power generation system. Again, this may be advantageous where the temperatures obtained are lower than those that are suitable for other power generation systems.
6. Industrial: Clearly, the *Otello*<sup>TM</sup> system would be beneficial in many industrial applications where heat would otherwise be wasted. Some examples include cement plants, kilns and ovens, any furnaces, and processes involving steam (such as food and/or chemical processes). The installation of an *Otello*<sup>TM</sup> system into the process would require only the inclusion of a heat exchanger to recover the waste heat and transfer it to the water bath. Users could then capture some of their wasted energy to generate electricity, which would reduce fuel/electricity consumption, energy costs, carbon emissions and any carbon-related penalties.

#### 7. TYPICAL WASTE HEAT TEMPERATURE AT HIGH TEMPERATURE RANGE FROM VARIOUS SOURCES

<b>Types of Device</b>	<b>Temperature, °C</b>
Nickel refining furnace	1370 –1650
Aluminium refining furnace	650-760
Zinc refining furnace	760-1100
Copper refining furnace	760- 815
Steel heating furnaces	925-1050
Copper reverberatory furnace	900-1100
Open hearth furnace	650-700
<b>Types of Device</b>	<b>Temperature, °C</b>
Cement kiln (Dry process)	620- 730
Glass melting furnace	1000-1550

Hydrogen plants	650-1000
Solid waste incinerators	650-1000
Fume incinerators	650-1450

### TYPICAL WASTE HEAT TEMPERATURE AT MEDIUM TEMPERATURE RANGE FROM VARIOUS SOURCES

Type of Device	Temperature, °C
Steam boiler exhausts	230-480
Gas turbine exhausts	370-540
Reciprocating engine exhausts	315-600
Reciprocating engine exhausts (turbo charged)	230- 370
Heat treating furnaces	425 - 650
Drying and baking ovens	230 - 600
Catalytic crackers	425 - 650
Annealing furnace cooling systems	425 - 650

#### Low Temperature Heat Recovery using “can do” OTELLO™

The following Table lists some heat sources in the low temperature range. In this range it is usually not practical to extract work from the source, though steam production may not be completely excluded if there is a need for low-pressure steam. Low temperature waste heat may be useful in a supplementary way for preheating purposes. **Otello™ can convert into clean electricity!**

### TYPICAL WASTE HEAT TEMPERATURE AT LOW TEMPERATURE RANGE FROM VARIOUS SOURCES

Source	Temperature, °C
Process steam condensate	55-88
<b>Cooling water from:</b>	
Annealing furnaces	66-230
Internal combustion engines	66-120
Drying, baking and curing ovens	93-230
Hot processed liquids	32-232
Hot processed solids	93-232

## 6. COLLABORATIVE PARTNERSHIPS

In addition to overseeing the development and deployment of the *Otello™* technology, IIL is currently in the process of bringing together a team of mature companies to facilitate the worldwide supply of parts and completed systems. The team currently includes the following members:

- International Innovations Limited (IIL): IIL is responsible for the ownership and maintenance of all intellectual property, including all improvements. IIL also acts as project manager and co-ordinator of product development programs.

- HYDAC International Group [www.hydac.com](http://www.hydac.com) : Hydac to be worldwide preferred parts supplier for the bladder and piston accumulators – ‘the heart of *Otello*<sup>TM</sup>’ – and other products such as, coolers / radiators where possible. Olaer’s global presence and supply chains will underpin the provision of *Otello*<sup>TM</sup> systems as the demand for waste heat recovery technology rapidly increases.
- HONEYWELL International Group [www.honeywell.com](http://www.honeywell.com) : to be preferred suppliers worldwide for - Control systems, instrumentation, valves and variable speed drives, as well as refrigerant gas.
- SONDEX [www.sondexaustralia.com.au](http://www.sondexaustralia.com.au) : Preferred suppliers in Australia for Heat Exchangers.
- NEWCASTEL INNOVATION LIMITED (NI) / Australia [www.newcastleinnovation.com.au](http://www.newcastleinnovation.com.au) is the commercial arm of Newcastle University and our / IIL Technical Development Centre for *Otello*<sup>TM</sup> & Moreamps heat recovery system / engines. Project OTELLO<sup>TM</sup> 1MW commenced 18<sup>th</sup> May 2009 at NI , see <http://www.newcastleinnovation.com.au/investment/energy.html> Energy and the Environment
- IMPERIAL COLLEGE LONDON / Dr Christos Markides [www.imperial.ac.uk](http://www.imperial.ac.uk) Optimisation demonstrators OTELLO & MOREAMPS thermal hydraulic generators project commencing 2010.

## 7. SUMMARY

The *Otello*<sup>TM</sup> system is a versatile waste heat recovery technology that can generate electricity from a wide variety of heat sources. It is based on the expansion of a refrigerant inside accumulators to pressurise a hydraulic medium, which is then used to drive a liquid turbine. The accumulators are mounted in a hot water bath or stand that can easily be interfaced with the heat source using common heat exchanger systems. The bladder / or piston system may have an efficiency advantage over vapour turbines under some operating conditions and it can be assembled from commercially available, off-the-shelf components. The *Otello*<sup>TM</sup> system could be applied to recover waste heat from stationary diesel generators, in solar thermal applications, to improve the output of conventional power stations, or in multiple industrial situations. In all these cases, the main *Otello*<sup>TM</sup> hardware would remain unchanged and standard, with only the heat transfer interface with the hot water bath being customised to the application. In this way, the *Otello*<sup>TM</sup> represents a low-cost, robust and attractive method for reducing fuel consumption, reducing carbon penalties and improving environmental sustainability. IIL is seeking collaborative partnerships with several international companies for the supply and sale of the *Otello*<sup>TM</sup> system, and is continually seeking to add new members to this highly competent team.

**[Finally, please view our website and see MOREAMPS Solar heat recovery system!](#)**

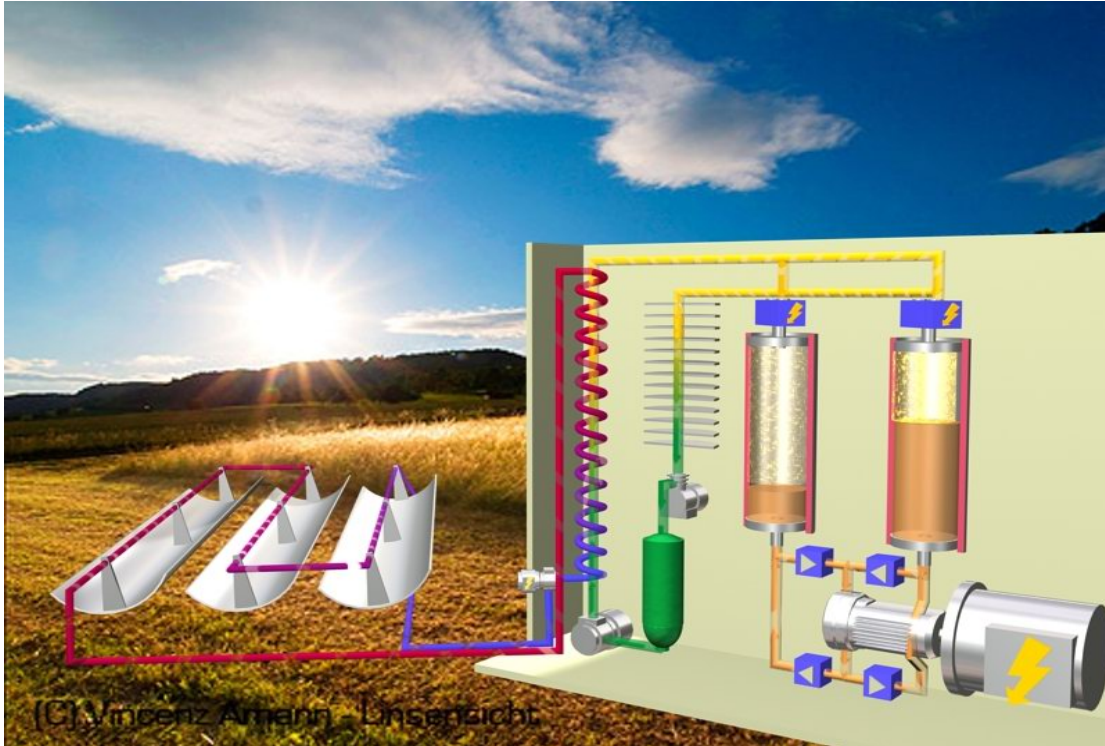

Above is the MOREAMPS solar thermal hydraulic generator.

Thank you for reading!

Mr. Stephen M. Hargreaves / Chairman & CEO  
[steve.hargreaves@internationalinnovations.com.au](mailto:steve.hargreaves@internationalinnovations.com.au) Phone Mobile: + 61 (0) 411879024

Written by Dr Nicholas Ward 3<sup>rd</sup> April 08,  
**UPDATED by Stephen Hargreaves 15<sup>th</sup> February 2010**